



# QUICK START GUIDE



## Automatic lamb feeder

### 5.1 Installation checklist

This document provides a brief overview of what to consider when installing a lamb feeder.

#### 1 Establish ground connection

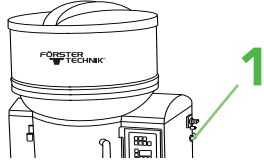

#### 2 Connect power

#### 3 Connect water

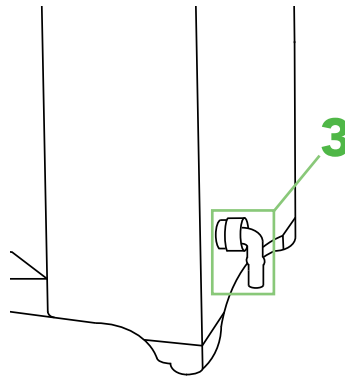

#### 4 Open hose fittings

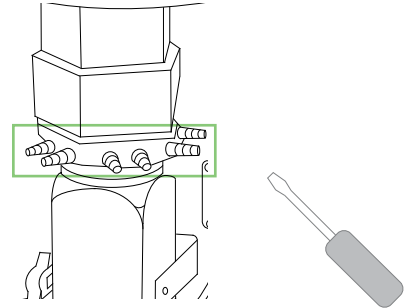

#### 5 Feeding station - suction hose

suction hose length max. 2 m [6,5']

Install the teat at its intended location on the front plate.

40cm [1,3'] above the lamb's floor

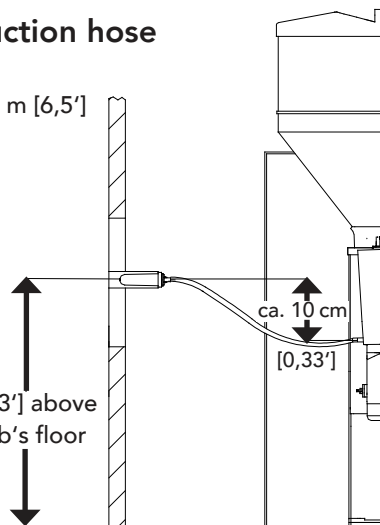

Mount the suction hose holder for cleaning - higher than the mixer position and near the suction points.

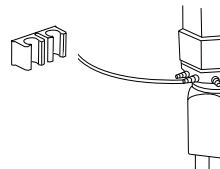

#### 6 Fix protection grid and fill the powder hopper

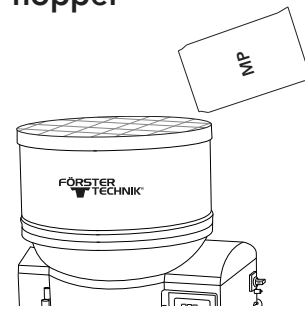

#### 7 Fill boiler



#### 8 New setup

Press and hold



All values set back to factory settings. Boiler is filled.

#### 9 Adjust target temperature

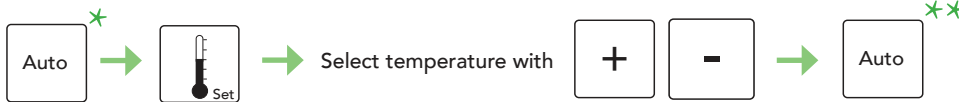

Hint: Auto button

\* press to stop Automatic mode

\*\* press to start Automatic mode

#### 10 Adjust portion size - Water

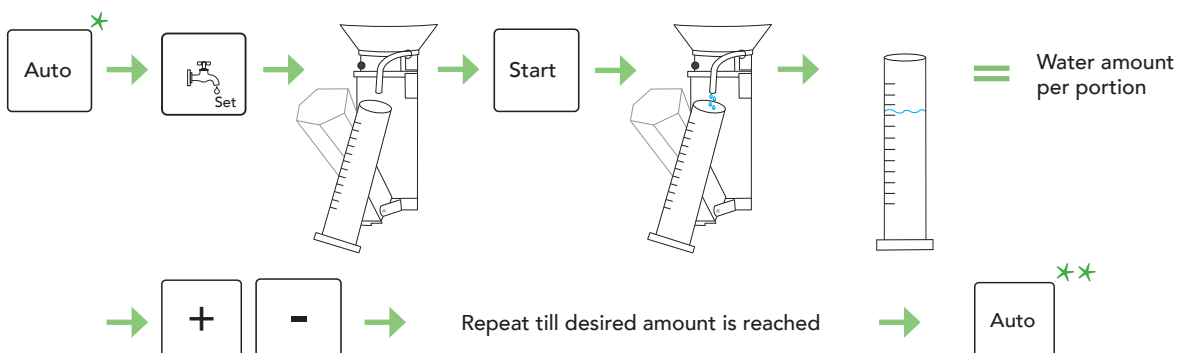

This checklist refers to the basic equipment of the Lamb Feeder. Not all available functions can be shown.

For detailed information and valid warnings as well as safety instructions, please refer to the instructions manual. (Status 21/07)

# QUICK START GUIDE

Automatic Lamb Feeder 5.1 Installation checklist

## 10 Adjust portion size - Milk powder (MP)

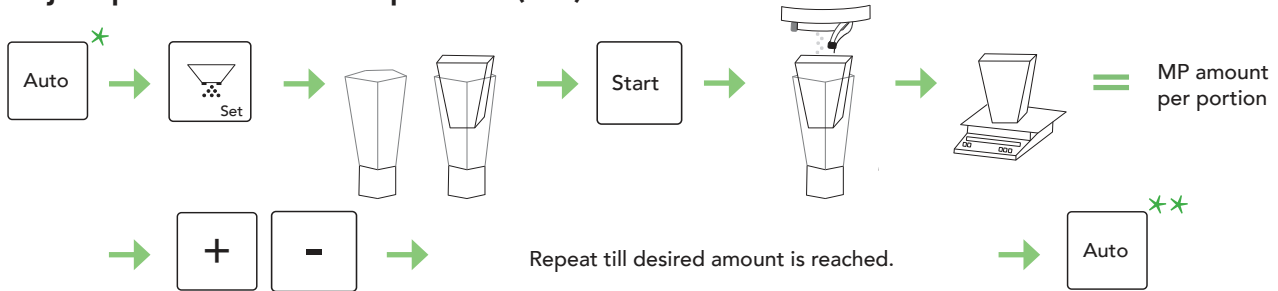

## 11 Cleaning - Mixer

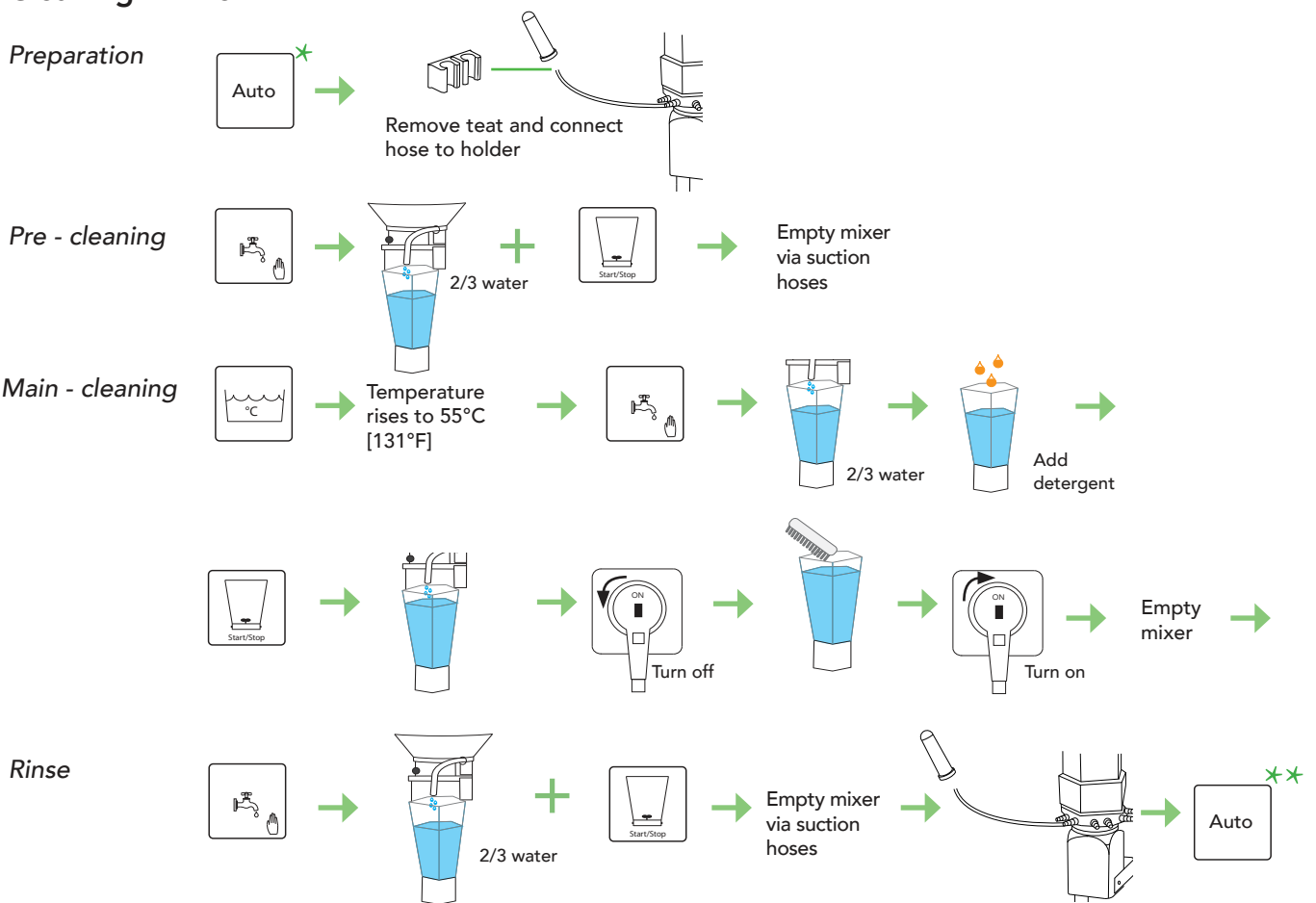

## 12 Cleaning - Suction hose

