

QUICK START GUIDE



Automatic calf feeder - Combi

1.4 Automatic calibration

This document provides a brief overview about what settings should be made for automatic calibration and what errors can occur.

1 Before calibration

Make sure mixer is not touching feeders housing.

2 Check that the hoses are fixed with the O-ring

3 Loosen or remove locking screw of the mixer

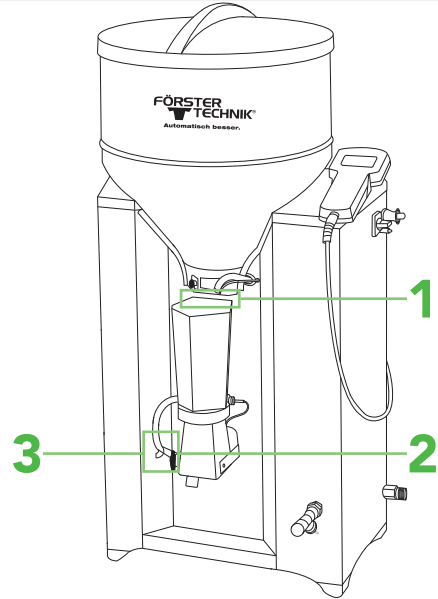

4 Settings

Times when the calibration should be carried out automatically.

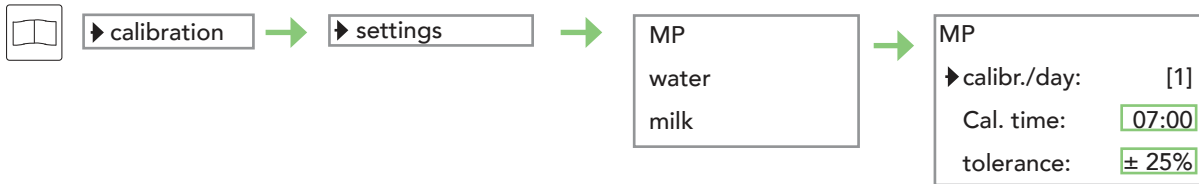

5 Check calibration scale

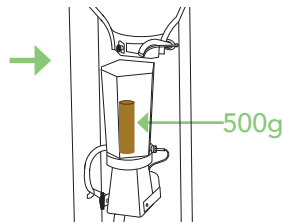
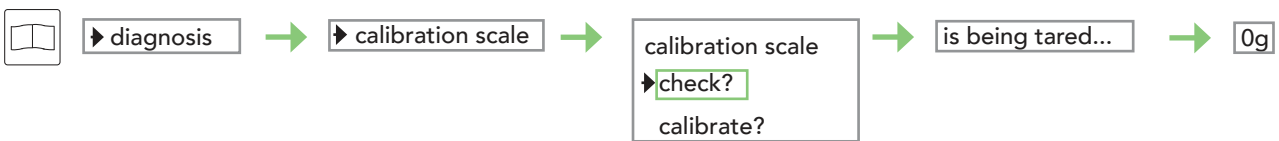

Insert the tare weight

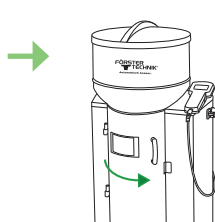

Close the fly protection door

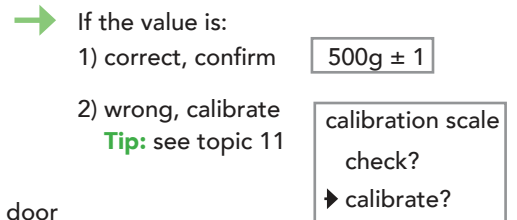

6 Manual start of automatic calibration

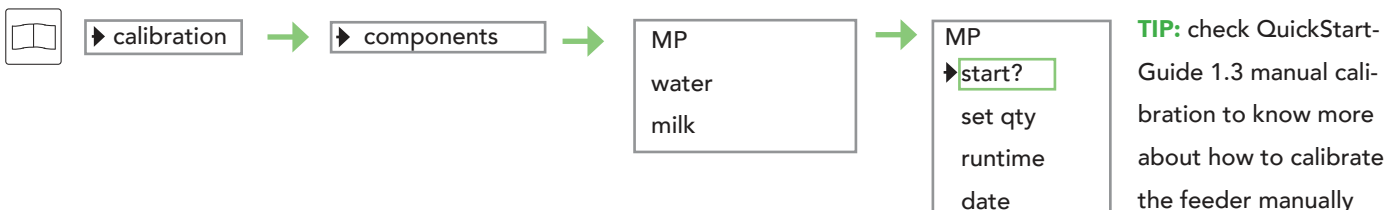

Troubleshooting

7 Warning: Calibration water HE/boiler

- Check water valves via diagnosis.
- Check if station or drain valves are leaking.
- Change calibration time to a moment when action can be observed (see 4).

Diagnosis

▶ valves
motors

< water boiler >

▶ autom. cal.: [yes]
cal. time: 07:00
tolerance: ± 25%

8 Warning: Calibration milk

- Check milk filter.
- Check milk valve via diagnosis.
- Check milk pump.
- Check if station or drain valves are leaking.
- Change calibration time to a moment when action can be observed (see 4).

Note: Auto calibration time for milk is an "from" time. Calibration is done with next entitled calf that enters station.

Diagnosis

▶ valves
motors

Milk

▶ calibr./day [1]
calibr. 1: 07:00
tolerance: ± 25%

9 Warning: Calibration milk powder

- Check powder supply outlet visually.
- Check powder supply via diagnosis.
- Check if station or drain valves are leaking.
- Change calibration time to a moment when action can be observed (see 4).

Note: Auto calibration time for milk powder is an "at" time. Calibration is done with next entitled calf that enters station.

Diagnosis

▶ valves
motors

Milk replacer

▶ calibr./day [1]
calibr. 1: 07:00
tolerance: ± 25%

10 Warning: Calibration

- 120 days after the last calibration of detergent, additives and concentrate.
Or if calibration value differs too much from the value of the last calibration for water HE, water boiler, MP and milk.
- Confirm warning with ENTER button.
- Recalibrate components that are displayed.
- Check with arrow left or right if there are more components to be calibrated.

< water boiler >

▶ start?
set qty: 500 ml
runtime: 6.00 s
date: 01.01.18

11 Procedure if checking the calibration scale failed

- Readjust the scale via diagnosis.
- Make sure the feeder is in a stable position.
- Make sure potential equalization is done correctly.
- Have it checked by a technician that the card of the calibration scale is correctly seated on the main board.

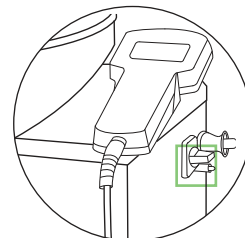

calibration scale

▶ check?

calibrate?